

Icematic®

Fabbricatori di ghiaccio
in cubetti

N301M



KS201/301

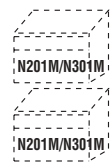

KN311



D201



D310

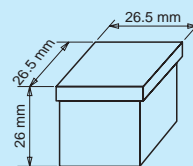

STANDARD

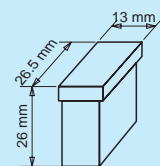

HALF DICE



MODULAR

Ice cubers

Eiswürfelerzeuger

Machines à glace en cubes

Màquinas productoras

de hielo en cubitos

Produzione di ghiaccio in 24 ore fino a
Ice produced for 24 hours up to
Eisproduktion in 24 Stunden bis zu
Production de glace en 24 h jusqu'à
Produccion de hielo en las 24 horas hasta

kg. 320

Raffreddamento unità condensatrice
Condensing unit cooling
Kondensatoreinheit
Rafroidissement de l'unité de condensation
Refrigeración de la unidad condensadora

aria
air
Luft
air
aire

o acqua: consumo n. 95 litri per ora*
or water: consumption n. 95 litres per hour*
oder Wasser: Verbrauch n. 95 liter pro Stunde*
ou eau: consommation n. 95 litres par heure*
o agua: consumo n. 95 litros para hora*

Potenza assorbita/Absorbed power/Leistungsaufnahme
Puissance absorbée/Potencia Absorbida

W 1600

Refrigerante/Refrigerant/Kältemittel
Réfrigérant/Refrigerant

R 404a

Attacco entrata acqua/Water inlet connection
Anschluss für Wasserzufluss/Prise entrée d'eau/conexión entrada agua

3/4" Gas

Attacco scarico acqua/Water output connection
Anschluss für Wasserabfluss/Prise écoulement d'eau
Conexión desagüe

mm. Ø 20

Alimentazione monofase/Single phase input/
Einphasige Spannung/Alimentation monophase
Alimentación monofásica

220V-240V - 50 Hz

Alimentazione voltaggi speciali:
Extra voltages:
Andere Spannungen:
Alimentation voltages spéciaux:
Otros voltajes especiales:

a richiesta
on request
Lieferbar auf Wunsch
sur demande
según pedido

Carrozzeria
External structure
Ausführung
Carrosserie
Carrocería

standard (1)
or inox

Peso netto/Net weight/Netto Gewicht
Poids net/Peso neto

kg. 73

(1) Pannelli in skinplate colore blu
Panles in skinplate blue coloured
Gehäuse aus-blauem skinplate
Panneaux en skinplate de couleur bleau
Panelos en skinplate de color azur noche

(*) con temperatura acqua 15 °C
with water temperature 15 °C
mit Wassertemperatur 15 °C
avec température eau 15 °C
con temperatura agua 15 °C

PRODUZIONE DI GHIACCIO
ICE PRODUCTION
EIS PRODUKTION
PRODUCTION DE GLACE
PRODUCCION DE HIELO

**RAFFR. AD ACQUA/WATER COOLED
WASSERGEKÜHLT/REFR. A EAU
REFR. A AGUA**

Temperatura acqua/Water temperature
Wassertemperatur/Température eau
Temperatura agua

°C	32°	21°	15°	10°	
10°	250	270	275	280	kg
21°	245	265	270	275	kg
32°	235	255	260	265	kg
38°	225	240	245	250	kg

Prod. ghiaccio in 24 h/Ice prod. per 24 h
Eisprod. in 24 h/Prod. de glace en 24 h
Prod. de hielo en 24 h

Temperatura ambiente
Ambient temperature
Raumtemperatur
Température ambiante
Temperatura ambiente

**RAFFR. AD ARIA/AIR COOLED
LUFTGEKÜHLT/REFR. A AIR
REFR. A AIRE**

Temperatura acqua/Water temperature
Wassertemperatur/Température eau
Temperatura agua

°C	32°	21°	15°	10°	
10°	260	290	305	320	kg
21°	240	265	275	280	kg
32°	195	210	220	225	kg
38°	174	180	188	190	kg

Prod. ghiaccio in 24 h/Ice prod. per 24 h
Eisprod. in 24 h/Prod. de glace en 24 h
Prod. de hielo en 24 h

Temperatura ambiente
Ambient temperature
Raumtemperatur
Température ambiante
Temperatura ambiente

Dimensioni / Dimensions / Masse / Dimensions / Dimensiones

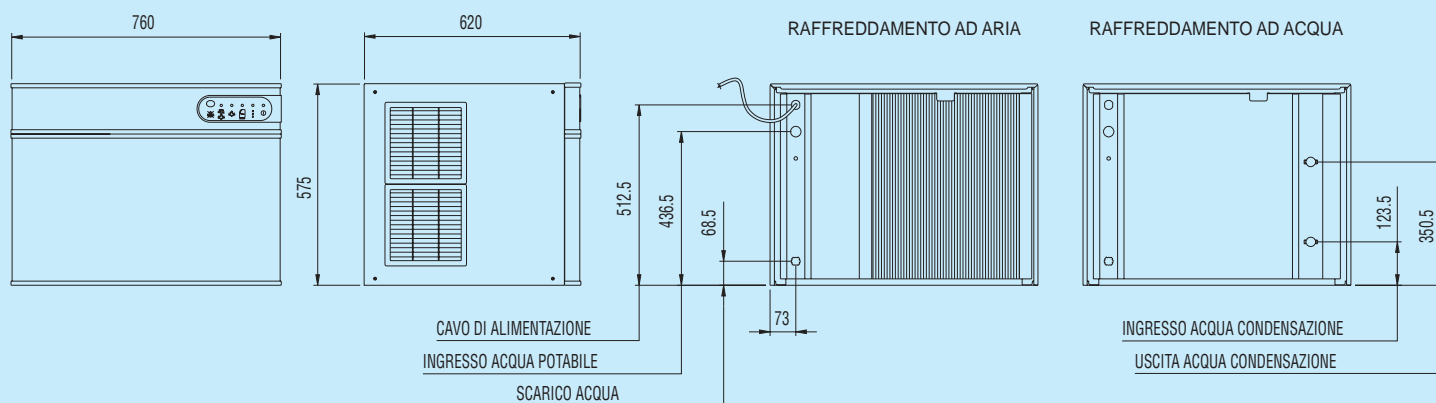

Castel MAC SpA

Via del Lavoro, 9 C.P. 67
I - 31033 Castelfranco Veneto (TV) Italy
Tel. (0423) 738452 - Fax (0423) 722811
E-mail: icematic@castelmac.it
Web-site: www.castelmac.it

I MODELLI E LE SPECIFICHE POSSONO ESSERE CAMBIATI IN QUALUNQUE
MOMENTO SENZA PREAVVISO
MODELS AND SPECIFICATIONS ARE SUBJECT TO BE CHANGED WITHOUT NOTICE
WIR BEHALTEN DAS RECHT VOR JEDERZEIT ANDERUNGEN DER MODELLE UND
DER TECHNISCHEN ANGABEN VORZUNEHMEN
LES MODELES ET CARACTERISTIQUES DES APPAREILS PEUVENT ETRE
CHANGES SANS PREAVIS
LOS MODELOS Y LAS ESPECIFICACIONES PODRAN MODIFICARSE EN CUALQUIER SIN PREVIO AVISO